

Telegesis	 SILICON LABS	TG-ETRX35X-PM-010-110
ETRX351 and ETRX357		Product Manual 1.20

ETRX35x ZIGBEE MODULES

PRODUCT MANUAL



Table of Contents

1	INTRODUCTION.....	5
1.1	Hardware Description.....	5
2	PRODUCT APPROVALS	6
2.1	FCC Approvals.....	6
2.1.1	FCC Labelling Requirements	7
2.2	IC (Industry Canada) Approvals	7
2.3	European Certification (ETSI).....	8
2.4	ICASA Approvals	8
2.5	Australia and New Zealand (C-Tick).....	8
2.6	Brazil.....	9
2.7	Declarations of Conformity	9
2.8	IEEE 802.15.4.....	9
2.9	The ZigBee Protocol	10
3	MODULE PINOUT	11
4	HARDWARE DESCRIPTION.....	13
4.1	Hardware Interface.....	13
5	FIRMWARE DESCRIPTION	14
5.1	Token Settings	15
5.2	Custom Firmware.....	15
5.3	Software Interface	16
6	ABSOLUTE MAXIMUM RATINGS	17
6.1	Environmental Characteristics.....	17
6.2	Recommended Operating Conditions.....	17
7	DC ELECTRICAL CHARACTERISTICS.....	18
8	DIGITAL I/O SPECIFICATIONS	20
9	A/D CONVERTER CHARACTERISTICS.....	21
10	AC ELECTRICAL CHARACTERISTICS.....	21
10.1	TX Power Characteristics.....	23
11	PHYSICAL DIMENSIONS.....	25
12	RECOMMENDED SOLDERING TEMPERATURE PROFILE	27
13	PRODUCT LABEL DRAWING	28
14	RECOMMENDED FOOTPRINT	29
14.1	Pad dimensions	29
14.2	Recommended Placement	30
14.3	Example carrier board.....	32
15	RELIABILITY TESTS.....	33
16	APPLICATION NOTES.....	33
16.1	Safety Precautions	33
16.2	Design Engineering Notes.....	33

16.3	Storage Conditions.....	34
17	PACKAGING	34
17.1	Embossed Tape.....	34
17.2	Component Orientation	35
17.3	Reel Dimensions.....	35
17.4	Packaging - bag	37
17.5	Packaging – carton	37
18	ORDERING INFORMATION.....	38
19	ROHS DECLARATION.....	39
20	DATA SHEET STATUS	39
21	RELATED DOCUMENTS	39



Image not shown actual size; enlarged to show detail.

The Telegesis ETRX351 and ETRX357 modules are low power 2.4GHz ZigBee modules, based on the latest Ember EM351 and EM357 single chip ZigBee™ solutions.

These 3rd generation modules have been designed to be integrated into any device without the need for RF experience and expertise. Utilizing the EmberZNet ZigBee stack, the ETRX35x enables you to add powerful wireless networking capability to your products and quickly bring them to market.

The module's unique AT-style command line interface allows designers to quickly integrate ZigBee technology without complex software engineering. For custom application development the ETRX35x series integrates with ease into Ember's InSight development environment.

Module Features

- Small form factor, SMT module 25mm x 19mm
- Side Castellations for easy soldering and optical inspection
- 2 antenna options: Integrated chip antenna or U.FL coaxial connector
- Industry's first ARM® Cortex-M3 based family of ZigBee modules
- Industry standard JTAG Programming and real time network level debugging via the Ember InSight Port
- 192kB (ETRX357) and 128kB (ETRX351) flash and 12kbytes of RAM
- Lowest Deep Sleep Current of sub 1µA and multiple sleep modes
- Wide supply voltage range (2.1 to 3.6V)
- Optional 32.768kHz watch crystal can be added externally
- Module ships with standard Telegesis AT-style command interface based on the ZigBee PRO feature set
- Can act as an End Device, Router or Coordinator
- 24 general-purpose I/O lines including analogue inputs (all GPIOs of the EM35x are accessible)
- Firmware upgrades via serial port or over the air (password protected)
- Hardware supported encryption (AES-128)
- CE, FCC and IC compliance, FCC modular approval
- Operating temperature range: -40°C to +85°C
- Long range version with a link budget of up to 124dB available in the same form factor

Radio Features

- Based on the Ember EM351 or EM357 single chip ZigBee solutions
- 2.4GHz ISM Band
- 250kbit/s over the air data rate
- 16 channels (IEEE802.15.4 Channel 11 to 26)
- +3dBm output power (+8dBm in boost mode)
- High sensitivity of -100dBm (-102dBm in boost mode) typically @ 1% packet error rate
- RX Current: 26mA, TX Current: 31mA at 3dBm
- Robust Wi-Fi and Bluetooth coexistence

Suggested Applications

- AMR – ZigBee Smart Energy applications
- Wireless Alarms and Security
- Home/Building Automation
- Wireless Sensor Networks
- M2M Industrial Controls
- Lighting and ventilation control
- Remote monitoring
- Environmental monitoring and control

Development Kit

- New Development kit containing everything required to set up a mesh network quickly and evaluate range and performance of the ETRX35x and its long-range version.
- AT-style software interface command dictionary can be modified for high volume customers.
- Custom software development available upon request.

Example AT-Style Commands

AT+BCAST	Send a Broadcast
AT+UCAST:<address>	Send a Unicast
AT+EN	Establish PAN network
AT+JN	Join PAN

At power-up the last configuration is loaded from non-volatile S-Registers, which can eliminate the need for an additional host controller.

1 Introduction

This document describes the Telegesis ETRX351 and ETRX357 ZigBee modules which have been designed to be easily integrated into another device and to provide a fast, simple and low cost wireless mesh networking interface.

The Telegesis ETRX3 series modules are based on the Ember ZigBee platform consisting of the single chip EM351 or EM357 combined with the ZigBee PRO compliant EmberZNet meshing stack. Integration into a wide range of applications is made easy using a simple AT style command interface and advanced hardware design.

The configurable functionality of the Telegesis AT Commandset often allows the ETRX3 series ZigBee modules to be used without an additional host microcontroller saving even more integration time and costs. In addition to the Telegesis AT Commandset, the ETRX351 and ETRX357 modules can be used with custom-built firmware whilst representing an ideal platform for custom firmware development in conjunction with the Ember development kits.

No RF experience or expertise is required to add this powerful wireless networking capability to your products. The ETRX351 and ETRX357 offer fast integration opportunities and the shortest possible time to market for your product.

1.1 Hardware Description

The main building blocks of the ETRX351 and ETRX357 are the single chip EM351 and EM357 SoCs from Ember, a 24MHz reference crystal and RF front-end circuitry optimized for best RF performance. The modules are available with on-board antenna or alternatively a U.FL coaxial connector for attaching external antennae. Modules with the U.FL connector are identified by the "HR" suffix.

The integrated antenna is an Antenova Rufa, and details of the radiation pattern etc are available from the Antenova website **Fehler! Verweisquelle konnte nicht gefunden werden..**

Module	Chip	Flash	RAM
ETRX351	EM351	128kB	12kB
ETRX351HR	EM351	128kB	12kB
ETRX357	EM357	192kB	12kB
ETRX357HR	EM357	192kB	12kB

Table 1: Memories

The ETRX351 and ETRX357 are used for ZigBee (www.zigbee.org) applications. In case it is desired to develop custom firmware instead of using the pre-loaded AT-Command interface, the Ember InSight toolchain, consisting of InSight Desktop™ together with a comprehensive integrated development environment (IDE), is required. The Ember development environment is currently not suitable for developing an IEEE802.15.4-only application that does not use the ZigBee layer.

2 Product Approvals

The ETRX351 and ETRX357 as well as the ETRX351HR and ETRX357HR have been designed to meet all national regulations for world-wide use. In particular the following certifications have been obtained:

2.1 FCC Approvals

The Telegesis ETRX351 and ETRX357 with integrated Antenna as well as the ETRX351HR and the ETRX357HR including the antennas listed in Table 2 have been tested to comply with FCC CFR Part 15 (USA) The devices meet the requirements for modular transmitter approval as detailed in the FCC public notice DA00.1407.transmitter. FCC statement:

This device complies with Part 15 of the FCC rules. Operation is subject to the following two conditions: (1) this device may not cause harmful interference, and (2) this device must accept any interference received, including interference that may cause undesired operation.



FCC ID: S4GEM35XA

Item	Part No.	Manufacturer	Type	Impedance	Gain
1	BT-Stubby (straight)	EAD Ltd. [6]	¼ Wave	50Ω	0dBi
2	BT-Stubby (right-angle)	EAD Ltd. [6]	¼ Wave	50Ω	0dBi
3	WH-2400-U2.5	Wellhope Wireless [7]	½ Wave	50Ω	2.5dBi
4	Rufa (on board)	Antenova	Chip	50Ω	2.1dBi (peak)

Table 2: Approved Antennae

While the applicant for a device into which the ETRX351 (ETRX357) or ETRX351HR (ETRX357HR) with an antenna listed in Table 2 is installed is not required to obtain a new authorization for the module, this does not preclude the possibility that some other form of authorization or testing may be required for the end product.

The FCC requires the user to be notified that any changes or modifications made to this device that are not expressly approved by Telegesis (UK) Ltd. may void the user's authority to operate the equipment.

When using the ETRX351HR and ETRX357HR with approved antennae, it is required to prevent end-users from replacing them with non-approved ones. The module and associated antenna must be installed to provide a separation distance of at least 20cm from all persons and must not transmit simultaneously with any other antenna or transmitter.

2.1.1 FCC Labelling Requirements

When integrating the ETRX351, ETRX357, ETRX351HR or ETRX357HR into a product it must be ensured that the FCC labelling requirements are met. This includes a clearly visible label on the outside of the finished product specifying the Telegesis FCC identifier (**FCC ID: S4GEM35XA**) as well as the FCC notice shown on the previous page. This exterior label can use wording such as **“Contains Transmitter Module FCC ID: S4GEM35XA”** or **“Contains FCC ID:S4GEM35XA”** although any similar wording that expresses the same meaning may be used.

2.2 IC (Industry Canada) Approvals

The Telegesis ETRX351 and ETRX357 with integrated Antenna as well as the ETRX351HR and the ETRX357HR modules have been approved by Industry Canada to operate with the antenna types listed in Table 2 with the maximum permissible gain and required antenna impedance for each antenna type indicated. Antenna types not included in this list, having a gain greater than the maximum gain indicated for that type, are strictly prohibited for use with this device.

IC-ID: 8735A-EM35XA

- This device complies with Industry Canada license-exempt RSS standard(s). Operation is subject to the following two conditions: (1) this device may not cause interference, and (2) this device must accept any interference, including interference that may cause undesired operation of the device.
- Under Industry Canada regulations, this radio transmitter may only operate using an antenna of a type and maximum (or lesser) gain approved for the transmitter by Industry Canada. To reduce potential radio interference to other users, the antenna type and its gain should be so chosen that the equivalent isotropically radiated power (e.i.r.p.) is not more than that permitted for successful communication.
- This module complies with FCC and Industry Canada RF radiation exposure limits set forth for general population. To maintain compliance, this module must not be co-located or operating in conjunction with any other antenna or transmitter.
- This device has been designed to operate with the antennas listed in Table 2, and having a maximum gain of 2.5 dBi. Antennas not included in this list or having a gain greater than 2.5 dBi are strictly prohibited for use with this device. The required antenna impedance is 50 ohms.

The labelling requirements for Industry Canada are similar to those of the FCC. Again a clearly visible label must be placed on the outside of the finished product stating something like “Contains Transmitter Module, IC: 8735A-EM35XA”, although any similar wording that expresses the same meaning may be used.

The integrator is responsible for the final product to comply to IC ICES-003 and FCC Part 15, Sub. B – Unintentional Radiators.

2.3 European Certification (ETSI)

The ETRX351, ETRX357, ETRX351HR and ETRX357HR have been certified to the following standards:

- Radio: EN 300 328:V1.8.1
- EMC: EN 301 489-17:V2.2.1
- Safety: EN 60950-1:2006 / A12:2011

For this purpose the ETRX351HR and ETRX357HR have been tested with the antennae listed in Table 2.

If the ETRX351, ETRX357, ETRX351HR or ETRX357HR module is incorporated into an OEM product, the OEM product manufacturer must ensure compliance of the final product to the European Harmonised EMC, and low voltage/safety standards. A Declaration of Conformity must be issued for each of these standards and kept on file as described in Annex II of the R&TTE Directive. The final product must not exceed the specified power ratings, antenna specifications and installation requirements as specified in this user manual. If any of these specifications are exceeded in the final product then a submission must be made to a notified body for compliance testing to all of the required standards.

The 'CE' marking must be applied to a visible location on any OEM product. For more information please refer to <http://ec.europa.eu/enterprise/faq/ce-mark.htm>. Customers assume full responsibility for learning and meeting the required guidelines for each country in their distribution market.

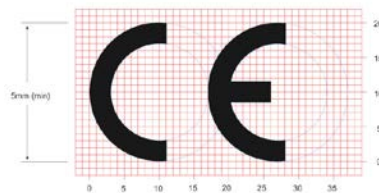

2.4 ICASA Approvals

The ETRX351, ETRX357, ETRX351HR and ETRX357HR have been certified to be used in South Africa.

2.5 Australia and New Zealand (C-Tick)

The ETRX351, ETRX357, ETRX351HR and ETRX357HR have been certified to be used in Australia and New Zealand.

In order to have a C-Tick mark on an end product integrating an ETRX35x device, a company must comply with a or b below.

- a). have a company presence in Australia.
- b). have a company/distributor/agent in Australia that will sponsor the importing of the end product.

2.6 Brazil

The ETRX357 and ETRX357HR have been certified to be used in Brazil.



2.7 Declarations of Conformity

Telegesis (UK) Ltd has issued Declarations of Conformity for all ETRX3 series ZigBee RF Modules, which cover Radio Emissions, EMC and Safety. These documents are available from our website or on request.

2.8 IEEE 802.15.4

IEEE 802.15.4 is a standard for low data-rate, wireless networks (raw bit-rate within a radio packet of 250kbps @2.4GHz) which focuses on low cost, low duty cycle, long primary battery life applications as well as mains-powered applications. It is the basis for the open ZigBee Protocol.

2.9 The ZigBee Protocol

The ZigBee Protocol is a set of standards for wireless connectivity for use between any devices over short to medium distances. The specification was originally ratified in December 2004, paving the way for companies to start making low-power networks a reality.

ZigBee uses the IEEE 802.15.4 radio specification running on the 2.4GHz band, plus three additional layers for networking, security and applications. What makes the specification unique is its use of a mesh network architecture which, in bucket chain style, passes data from one node to the next until it lands at its destination. The network is self-healing and adapts its routing as link quality changes or nodes move. Furthermore, nodes can be defined as End Devices which do not act as routers, but can therefore be put into a low-power sleep state.

The enhanced version of the ZigBee standard (or ZigBee 2006) was released in December 2006, adding new features and improvements to the only global wireless communication standard enabling the development of easily deployable low-cost, low-power, monitoring and control products for homes, commercial buildings and industrial plant monitoring. In 2007 the ZigBee Alliance introduced the PRO featureset which offers advantages over earlier versions, including

- Truly self healing mesh networking
- Messages can now travel up to 30 hops
- Source-Routing for improved point to multipoint message transmission
- Improved security including Trust-Centre link keys
- New message types and options

The Telegesis AT-Commandset, which by default ships on all ETRX3 series products is based on the ZigBee PRO featureset. For more information on the Telegesis AT-Commandset please refer to the separate documentation at www.telegesis.com.

3 Module Pinout

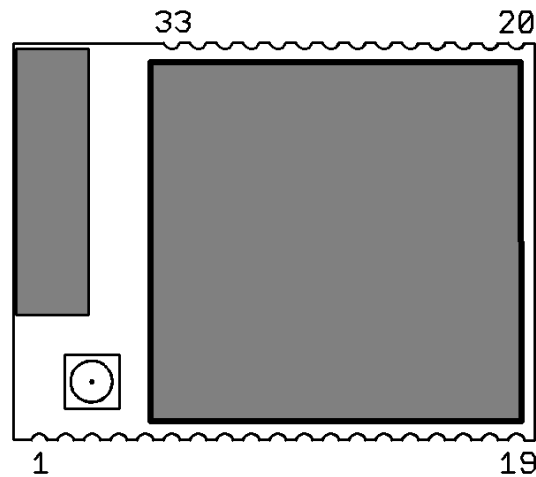

Figure 1: ETRX3 series Module Pinout (top view)

The table below gives details about the pin assignment for direct SMD soldering of the ETRX3 series modules to the application board. For more information on the alternate functions please refer to [2]. Also refer to the Telegesis AT Commandset documentation and the Telegesis development kit documentation to understand how the pre-programmed firmware makes use of the individual I/Os.

All GND pads are connected within the module, but for best RF performance all of them should be grounded externally ideally to a ground plane.

“Important Note: If designers would like to keep open the option of using either standard or long range modules in the same product please note the following. The ETRX35x series and the ETRX35x-LRS series of modules are footprint compatible, but on the ETRX35x-LRS series pins PB0 and PC5 of the EM357 are used internally to control the front-end module and are not available to the user.”

ETRX35x Pad	Name	EM35x Pin	Default use	Alternate Functions
1	GND	GND	GND	
2	PC5 {1}	11		TX_ACTIVE
3	PC6	13	I/O	OSC32B, nTX_ACTIVE
4	PC7	14	I/O	OSC32A, OSC32_EXT
5	PA7 {5}	18	I/O	TIM1C4
6	PB3 {2,3}	19	I/O, CTS	SC1nCTS, SC1SCLK, TIM2C3
7	nReset {6}	12	nReset	
8	PB4 {2,3}	20	I/O, RTS	TIM2C4, SC1nRTS, SC1nSSEL
9	PA0	21	I/O	TIM2C1, SC2MOSI
10	PA1	22	I/O	TIM2C3, SC2SDA, SC2MISO
11	PA2	24	I/O	TIM2C4, SC2SCL, SC2SCLK
12	PA3	25	I/O	SC2nSSEL, TRACECLK, TIM2C2
13	GND	GND	GND	
14	PA4	26	I/O	ADC4, PTI_EN, TRACEDATA
15	PA5 {4}	27	I/O	ADC5, PTI_DATA, nBOOTMODE, TRACEDATA3
16	PA6 {5}	29	I/O	TIM1C3
17	PB1 {3}	30	TXD	SC1MISO, SC1MOSI, SC1SDA, SC1TXD, TIM2C1
18	PB2 {3}	31	RXD	SC1MISO, SC1MOSI, SC1SCL, SC1RXD, TIM2C2
19	GND	GND	GND	
20	GND	GND	GND	
21	JTCK	32		SWCLK
22	PC2	33	I/O	JTDO, SWO
23	PC3	34	I/O	JTDI
24	PC4	35	I/O	JTMS, SWDIO
25	PB0	36	I/O, IRQ	VREF, IRQA, TRACECLK, TIM1CLK, TIM2MSK
26	PC1	38	I/O	ADC3, SWO, TRACEDATA0
27	PC0 {5}	40	I/O	JRST, IRQD, TRACEDATA1
28	PB7 {5}	41	I/O	ADC2, IRQC, TIM1C2
29	PB6 {5}	42	I/O	ADC1, IRQB, TIM1C1
30	PB5	43	I/O	ADC0, TIM2CLK, TIM1MSK
31	GND	GND	GND	
32	Vcc	Vcc	Vcc	
33	GND	GND	GND	

Table 3: Pin Information
Notes:

- {1} When the alternate function is selected, TX_ACTIVE becomes an output that indicates that the EM35x radio circuit is in transmit mode. PC5 is not usable on the long range version of the ETRX35x as this GPIO is used internally as TX_ACTIVE to control the external RF frontend.
- {2} The serial UART connections TXD, RXD, CTS and RTS are PB1, PB2, PB3 and PB4 respectively. The device sends its data on TXD and receives on RXD.
- {3} When using the Telegesis AT Commandset, RTS/CTS handshaking is selectable in firmware. See the AT Command Manual.
- {4} If PA5 is driven low at power-up or reset the module will boot up in the bootloader
- {5} PA6, PA7, PB6, PB7 and PC0 can drive high current (see section 8)
- {6} nRESET is level-sensitive, not edge-sensitive. The module is held in the reset state while nRESET is low

See also the table “Module pads and functions” in the ETRX357 Development Kit Product Manual. Refer to Ember’s EM357 manual for details of the alternate functions and pin names.

4 Hardware Description

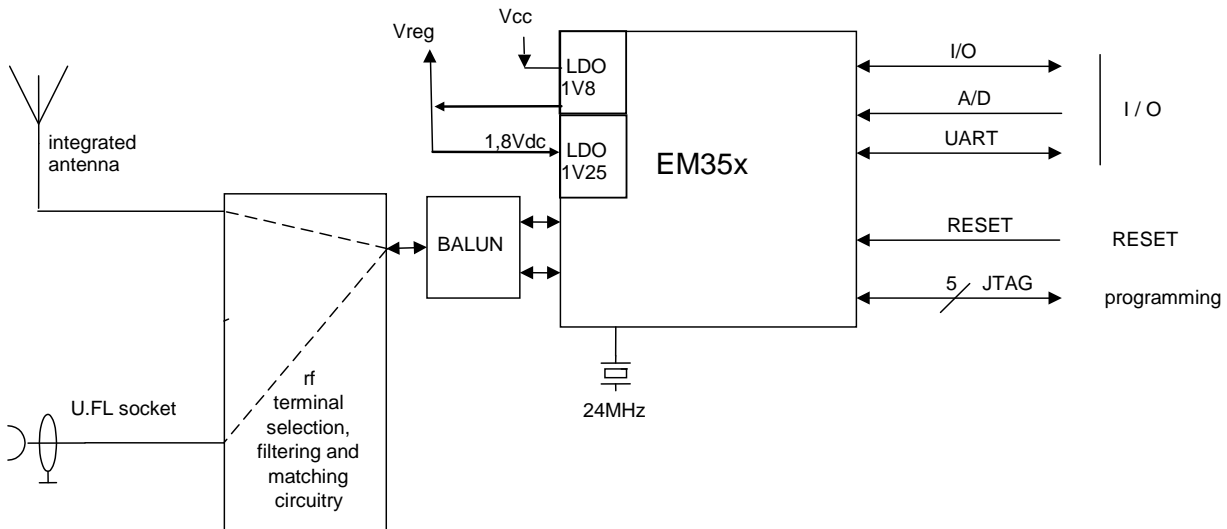

Figure 2: Hardware Diagram

The ETRX351, ETRX351HR, ETRX357 and ETRX357HR are based on the Ember EM351 and EM357 respectively. The EM351 and EM357 are fully integrated 2.4GHz ZigBee transceivers with a 32-bit ARM® Cortex M3™ microprocessor, flash and RAM memory, and peripherals.

The industry standard serial wire and JTAG programming and debugging interfaces together with the standard ARM system debug components help to streamline any custom software development.

In addition to this a number of MAC functions are also implemented in hardware to help maintaining the strict timing requirements imposed by the ZigBee and IEEE802.15.4 standards.

The new advanced power management features allow faster wakeup from sleep and new power down modes allowing this 3rd generation module to offer a longer battery life than any 2nd generation modules on the market.

The EM35x has fully integrated voltage regulators for both required 1.8V and 1.25V supply voltages. The voltages are monitored (brown-out detection) and the built in power-on-reset circuit eliminates the need for any external monitoring circuitry. An optional 32.768 kHz watch crystal can be connected externally to pads 3 and 4 in case more accurate timing is required. To utilize the external watch crystal custom firmware is required.

4.1 Hardware Interface

All GPIO pins of the EM351 or EM357 are accessible on the module's pads. Whether signals are used as general purpose I/Os, or assigned to a peripheral function like ADC is set by the firmware. When using the Telegesis AT Commandset please refer to the AT Commandset manual and the development kit manual for this information and when developing custom firmware please refer to the EM35x datasheet [2].

5 Firmware Description

The modules will be pre-loaded with a standalone bootloader which supports over-the-air bootloading as well as serial bootloading of new firmware.

In order to enter the standalone bootloader using a hardware trigger pull PA5 to ground and power-cycle or reset the module. To avoid entering the standalone bootloader unintentionally make sure not to pull this pin down during boot-up unless the resistance to ground is $>10k\Omega$. (A pull-up is not required).

In addition to the standalone bootloader the modules also contain the current release of the Telegesis AT-style command interface as described in the Telegesis AT command dictionary and the Telegesis user guide. Check www.telegesis.com for updates. Each module comes with a unique 64-bit 802.15.4 identifier which is stored in non-volatile memory. The commands and responses pass through the serial port of the ETRX35x as ASCII text, so a simple terminal application will usually suffice. We provide Telegesis Terminal for interaction with the module but it is not an essential feature.

The pre-loaded AT-style command interface firmware is based on the latest EmberZNet meshing stack which implements routers/coordinators as well as (sleepy) end devices. [End devices have no routing responsibility and therefore are allowed to go to sleep, whilst still being able to send and receive messages via a parent router. In addition to classical sleepy and non-sleepy end devices the module firmware also supports mobile (sleepy) end devices capable of changing their parent quickly whenever they change their position within the network.]

A router is typically a mains powered device whilst a sleepy end device (SED) can be battery powered.

The module is also able to act as a coordinator and Trust Centre through external host control. The AT style command line supplies all the tools required to set up and manage a ZigBee network by allowing easy access to the low-level functionality of the stack.

The Telegesis firmware uses the meshing and self healing EmberZNet PRO stack to overcome many of the limitations of the tree network topology of the ZigBee 2006 stack by using the ZigBee PRO featureset.

The Telegesis firmware allows low-level access to physical parameters such as channel and power level. Parameters that define the functionality of the ETRX35x module and also allow standalone functionality are saved in non-volatile memory organised in so-called S-Registers. The SPI and I2C buses are not supported by the current firmware release, but can be used with custom firmware.

5.1 Token Settings

The ETRX3 Series Modules' tokens will be pre-programmed with the settings shown in the table below.

Token	Description	TG Default
MFG_CIB_OBS	Option Bytes	<not written>
MFG_CUSTOM_VERSION	Optional Version Number	<not written>
MFG_CUSTOM_EUI_64	Custom EUI	<not written>
MFG_STRING	Device Specific String	TELEGESIS
MFG_BOARD_NAME	Hardware Identifier	<Order Code>
MFG_MANUF_ID	Manufacturer ID	0x1010
MFG_PHY_CONFIG	Default Power Settings	0xFF26
MFG_BOOTLOAD_AES_KEY	Bootloader Key	<not written>
MFG_EZSP_STORAGE	EZSP related	<not written>
MFG_CBKE_DATA	SE Security	<not written>
MFG_INSTALLATION_CODE	SE Installation	<not written>
MFG_OSC24M_BIAS_TRIM	Crystal Bias	<not written>

Table 4. Manufacturing tokens

5.2 Custom Firmware

For high volume customers the firmware can be customised on request. In addition to this the ETRX3 series of modules is an ideal platform for developing custom firmware. In order to develop custom firmware the Ember Insight toolchain is required.

5.3 Software Interface

Using the default firmware the ETRX35x is controlled using a simple AT-style command interface and (mostly) non-volatile S-Registers. In order to get a full listing of all the available AT-Commands, please refer to the AT command dictionary document which corresponds to the firmware revision you intend to use.

In addition to the command dictionary there are user guides explaining the features of the firmware in more detail. If you need to find out which firmware resides on your module simply type **"ATI"** followed by a carriage return and you will be prompted with the module's manufacturing information.

The Development Kit manual describes how to upgrade the firmware either via a serial link or over the air.

6 Absolute Maximum Ratings

No.	Item	Symbol	Absolute Maximum Ratings	Unit
1	Supply voltage	V _{CC}	-0.3 to +3.6	Vdc
2	Voltage on any Pad	V _{in}	-0.3 to V _{CC} +0.3	Vdc
3	Voltage on any Pad pin (PA4, PA5, PB5, PB6, PB7, PC1), when used as an input to the general purpose ADC with the low voltage range selected	V _{in}	-0.3 to +2.0	Vdc
4	Module storage temperature range	T _{stg}	-40 to +105	°C
5	Reel storage temperature range	T _{strgreel}	0 to 75	°C
6	Operating temperature range	T _{op}	-40 to +85	°C
7	Input RF level	P _{max}	15	dBm
8	Reflow temperature	T _{Death}	Please refer to chapter 12	°C

Table 5: Absolute Maximum Ratings

The absolute maximum ratings given above should under no circumstances be violated. Exceeding one or more of the limiting values may cause permanent damage to the device.



Caution! ESD sensitive device. Precautions should be used when handling the device in order to prevent permanent damage.

6.1 Environmental Characteristics

No.	Item	Symbol	Absolute Maximum Ratings	Unit
1	ESD on any pad according to Human Body Model (HBM) circuit description	V _{THHBM}	±2	kV
2	ESD on non-RF pads according to Charged Device Model (CDM) circuit description	V _{THCDM}	±400	V
3	ESD on RF terminal according to Charged Device Model (CDM) circuit description	V _{THCDM}	±225	V
4	Moisture Sensitivity Level	MSL	MSL3	

Table 6: Absolute Maximum Ratings

6.2 Recommended Operating Conditions

No.	Item	Condition / Remark	Symbol	Value			Unit
				Min	Typ	Max	
1	Supply voltage		V _{CC}	2.1		3.6	Vdc
2	RF Input Frequency		f _c	2405		2480	MHz
3	RF Input Power		p _{IN}			0	dBm
4	Operating temperature range		T _{op}	-40		+85	°C

Table 7: Recommended Operating Conditions

7 DC Electrical Characteristics

V_{CC} = 3.0V, T_{AMB} = 25°C, NORMAL MODE (non-Boost) unless otherwise stated

No.	Item	Condition / Remark	Symbol	Value			Unit
				Min	Typ	Max	
1	Module supply voltage		V _{CC}	2.1		3.6	Vdc
Deep Sleep Current							
2	Quiescent current, internal RC oscillator disabled		I _{SLEEP}		0.4		μA
3	Quiescent current, internal RC oscillator enabled		I _{SLEEP}		0.7		μA
4	Quiescent current, including 32.768kHz oscillator		I _{SLEEP}		1.0		μA
5	Quiescent current including internal RC oscillator and 32.768kHz oscillator		I _{SLEEP}		1.3		μA
Reset Current							
6	Quiescent current nReset asserted		I _{RESET}		1.2	2.0	mA
Processor and Peripheral Currents							
7	ARM® Cortex™ M3, RAM and flash memory	25°C, 12MHz Core clock	I _{MCU}		6.0		mA
8	ARM® Cortex™ M3, RAM and flash memory	25°C, 24MHz Core clock	I _{MCU}		7.5		mA
9	ARM® Cortex™ M3, RAM and flash memory sleep current	25°C, 12MHz Core clock	I _{MCU}		3.0		mA
10	ARM® Cortex™ M3, RAM and flash memory sleep current	25°C, 6MHz Core clock	I _{MCU}		2.0		mA
11	Serial controller current	Per serial controller at max. clock rate	I _{SC}		0.2		mA
12	General purpose timer current	Per timer at max. clock rate	I _{TIM}		0.25		mA
13	General purpose ADC current	Max. Sample rate, DMA	I _{ADC}		1.1		mA
RX Current							
14	Radio receiver MAC and Baseband	ARM® Cortex™ M3 sleeping.	I _{RX}		22		mA
15	Receive current consumption	Total, 12MHz clock speed	I _{RX}		25		mA
16	Receive current consumption	Total, 24MHz clock speed	I _{RX}		26.5		mA
17	Receive current consumption BOOST MODE	Total, 12MHz clock speed	I _{RX}		27		mA
18	Receive current consumption BOOST MODE	Total, 24MHz clock speed	I _{RX}		28.5		mA

TX Current							
19	Transmit current consumption	at +3dBm module output power	I_{TXVCC}		31		mA
20	Transmit Current consumption BOOST MODE	at +8dBm module output power	I_{TXVCC}		42		mA
21	Transmit current consumption	at +0dBm module output power	I_{TXVCC}		28.5		mA
22	Transmit current consumption	at min. module output power	I_{TXVCC}		23.5		mA
23	Wake time from deep sleep	From wakeup event to 1 st instruction			100		μ s
24	Shutdown time	From last instruction into deep sleep			5		μ s

Table 8: DC Electrical Characteristics

Please Note: The average current consumption during operation is dependent on the firmware and the network load, therefore these figures are provided in the command dictionary of the respective firmware.

8 Digital I/O Specifications

The digital I/Os of the ETRX35x module

$V_{CC} = 3.0V$, $T_{AMB} = 25^{\circ}C$, NORMAL MODE unless otherwise stated

No.	Item	Condition / Remark	Symbol	Value			Unit
				Min	Typ	Max	
1	Low Schmitt switching threshold	Schmitt input threshold going from high to low	V_{SWIL}	$0.42 \times V_{CC}$		$0.5 \times V_{CC}$	Vdc
2	High Schmitt switching threshold	Schmitt input threshold going from low to high	V_{SWIH}	$0.62 \times V_{CC}$		$0.8 \times V_{CC}$	Vdc
3	Input current for logic 0		I_{IL}			-0.5	μA
4	Input current for logic 1		I_{IH}			0.5	μA
5	Input Pull-up resistor value		R_{IPU}	24	29	34	k Ω
6	Input Pull-down resistor value		R_{IPD}	24	29	34	k Ω
7	Output voltage for logic 0	$I_{OL} = 4mA$ (8mA) for standard (high current) pads	V_{OL}	0		$0.18 \times V_{CC}$	V
8	Output voltage for logic 1	$I_{OH} = 4mA$ (8mA) for standard (high current) pads	V_{OH}	$0.82 \times V_{CC}$		V_{CC}	V
9	Output Source Current	Standard current pad	I_{OHS}			4	mA
10	Output Sink current	Standard current pad	I_{OLS}			4	mA
11	Output Source Current	High current pad (1)	I_{OHH}			8	mA
12	Output Sink current	High current pad (1)	I_{OLH}			8	mA
13	Total output current		$I_{OH} + I_{OL}$			40	mA

Table 9. Digital I/O Specifications

Notes

- 1) High current pads are PA6, PA7, PB6, PB7, PC0

9 A/D Converter Characteristics

The ADC is a first-order sigma-delta converter. For additional information on the ADC please refer to section 10 of the EM35x datasheet.

No.	Item	
1	A/D resolution	Up to 14 bits
2	A/D sample time for 7-bit conversion	5.33µs
3	A/D sample time for 14-bit conversion	682µs
4	Reference Voltage	1.2V
5	Max current drain from Vref pin	1mA

Table 10. A/D Converter Characteristics

10 AC Electrical Characteristics

$V_{CC} = 3.0V$, $T_{AMB} = 25^{\circ}C$, NORMAL MODE measured at 50Ω terminal load connected to the U.FL socket

No.	Receiver	Value			Unit
		Min	Typ	Max	
1	Frequency range	2400		2500	MHz
2	Sensitivity for 1% Packet Error Rate (PER)		-100	-94	dBm
3	Sensitivity for 1% Packet Error Rate (PER) BOOST MODE		-102	-96	dBm
4	Saturation (maximum input level for correct operation)	0			dBm
5	High-Side Adjacent Channel Rejection (1% PER and desired signal -82dBm acc. to [1])		41		dB
6	Low-Side Adjacent Channel Rejection (1% PER and desired signal -82dBm acc. to [1])		44		dB
7	2 nd High-Side Adjacent Channel Rejection (1% PER and desired signal -82dBm acc. to [1])		53		dB
8	2 nd Low-Side Adjacent Channel Rejection (1% PER and desired signal -82dBm acc. to [1])		52		dB
9	Channel Rejection for all other channels (1% PER and desired signal -82dBm acc. to [1])		40		dB
10	802.11g rejection centred at +12MHz or -13MHz (1% PER and desired signal -82dBm acc. to [1])		36		dB
11	Co-channel rejection (1% PER and desired signal -82dBm acc. to [1])		-6		dBc
12	Relative frequency error (2x40ppm required by [1])	-120		120	ppm
13	Relative timing error (2x40ppm required by [1])	-120		120	ppm
14	Linear RSSI range	40			dB
15	Output power at highest power setting NORMAL MODE BOOST MODE	0	3 8		dBm
16	Output power at lowest power setting		-55		dBm
17	Error vector magnitude as per IEEE802.15.4		5	15	%
18	Carrier frequency error	-40 (1)		40 (1)	ppm
19	PSD mask relative 3.5MHz distance from carrier	-20			dB
20	PSD mask absolute 3.5MHz distance from carrier	-30			dBm

Table 11. AC Electrical Characteristics

Notes

(1) Applies across the full ranges of rated temperature and supply voltage.

Please Note: For the relationship between EM35x power settings and module output power please relate to chapter 10.1 of this document. When developing custom firmware the output power settings described in this document relate directly to the EM35x power settings accessible via the Ember stack API.

No.	Synthesiser Characteristics	Limit			Unit
		Min	Typ	Max	
22	Frequency range	2400		2500	MHz
23	Frequency resolution		11.7		kHz
24	Lock time from off state, with correct VCO DAC settings			100	µs
25	Relock time, channel change or Rx/Tx turnaround			100	µs
26	Phase noise at 100kHz offset		-75dBc/Hz		
27	Phase noise at 1MHz offset		-100dBc/Hz		
28	Phase noise at 4MHz offset		-108dBc/Hz		
29	Phase noise at 10MHz offset		-114dBc/Hz		

Table 12: Synthesiser Characteristics

No.	Power On Reset (POR) Specifications	Limit			Unit
		Min	Typ	Max	
30	V _{CC} POR release	0.62	0.95	1.2	Vdc
31	V _{CC} POR assert	0.45	0.65	0.85	Vdc

Table 13: Power On Reset Specifications

No.	nRESET Specifications	Limit			Unit
		Min	Typ	Max	
32	Reset Filter Time constant	2.1	12	16	µs
33	Reset Pulse width to guarantee a reset	26			µs
34	Reset Pulse width guaranteed not to cause reset	0		1	µs
35	Input pull-up resistor value while the chip is not reset	24	29	34	kΩ
36	Input pull-up resistor value while the chip is reset	12	14.5	17	kΩ

Table 14: nReset Specifications

10.1 TX Power Characteristics

The diagrams below show the typical output power and module current in dependency on module EM35x power setting. Power settings above 3dBm have Boost Mode enabled. Please note that the output power is independent of the supply voltage as the radio is supplied by an internally regulated voltage.

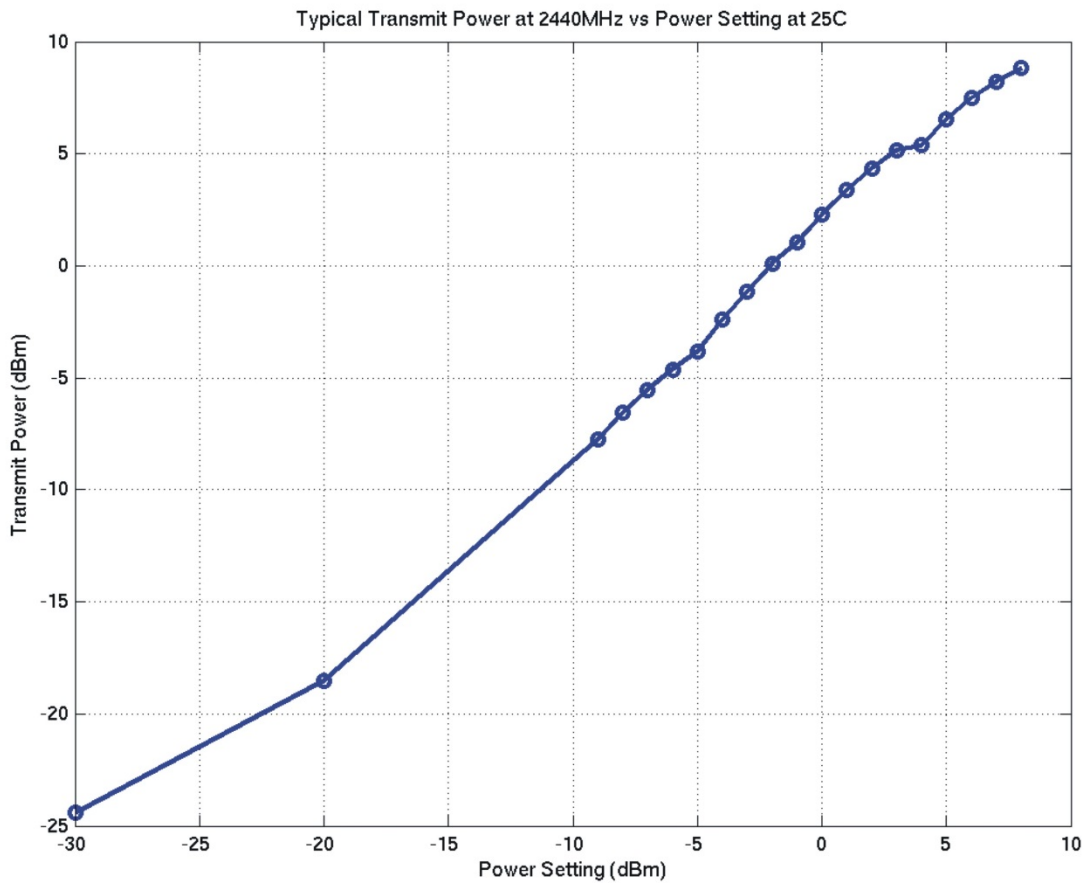

Figure 3: Output Power vs. Power Setting

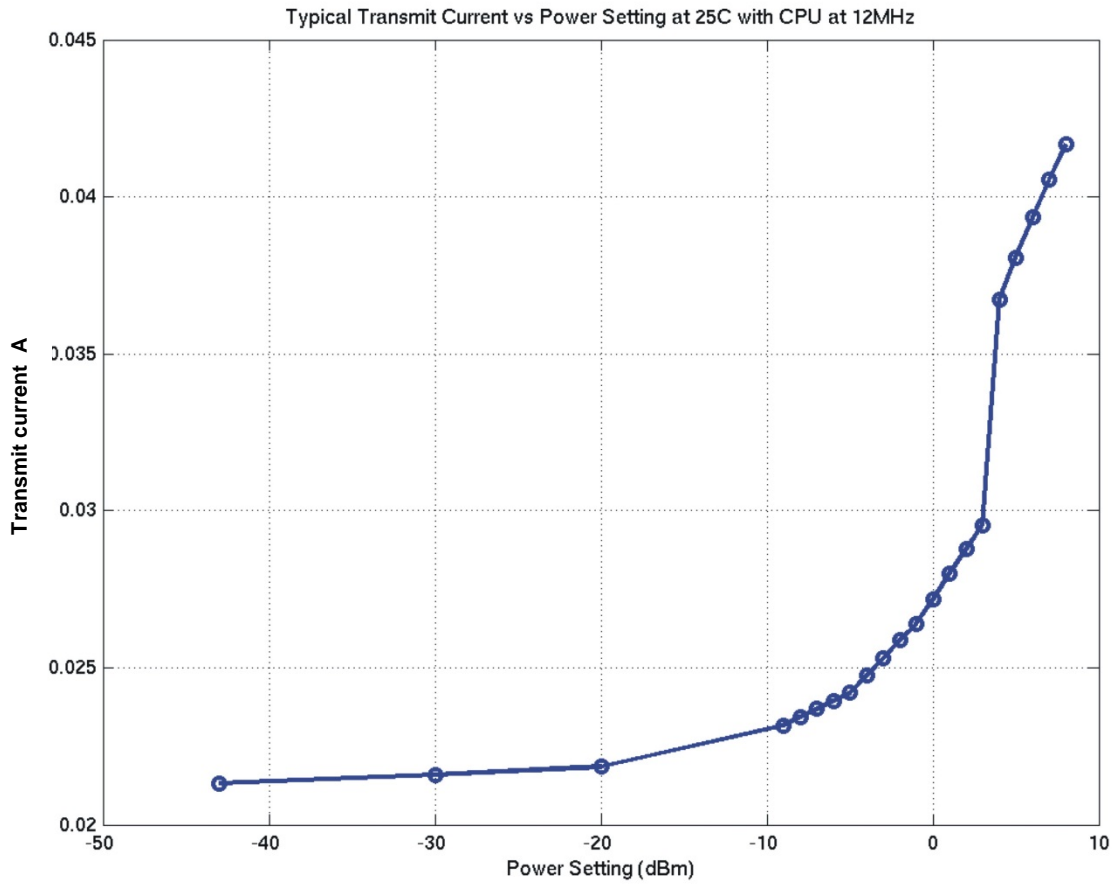

Figure 4: Module Current vs. Power Setting

11 Physical Dimensions

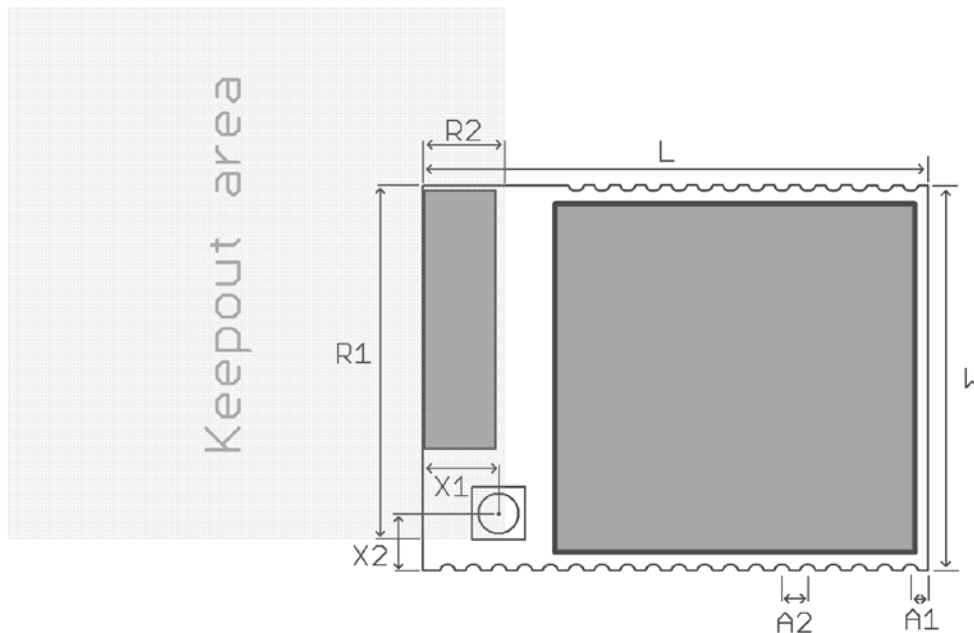

Figure 5: ETRX3 Physical Dimensions

Symbol	Explanation	Typical Distance	Tolerances
L	Length of the module	25.0mm	±0.13mm
W	Width of the module	19.0mm	±0.13mm
H	Height of the module	3.8mm	±0.1mm
A1	Distance centre of pad PCB edge	0.9mm	±0.13mm
A2	Pitch	1.27mm	n/a
R1	Keep-out Zone from corner of PCB	17.5mm	n/a
R2	Keep-out Zone from corner of PCB	4.1mm	n/a
X1	Distance centre of Antenna connector PCB edge	3.8mm	±0.13mm
X2	Distance centre of Antenna connector PCB edge	2.8mm	±0.13mm

Table 15: ETRX3 Physical Dimensions

For ideal RF performance when using the on-board antenna, the antenna should be located at the corner of the carrier PCB. There should be no components, tracks or copper planes in the keep-out area which should be as large as possible. When using the U.FL RF connector the keep-out area does not have to be obeyed. **Note:** The modules' transmit/receive range will depend on the antenna used and also the housing of the finished product.

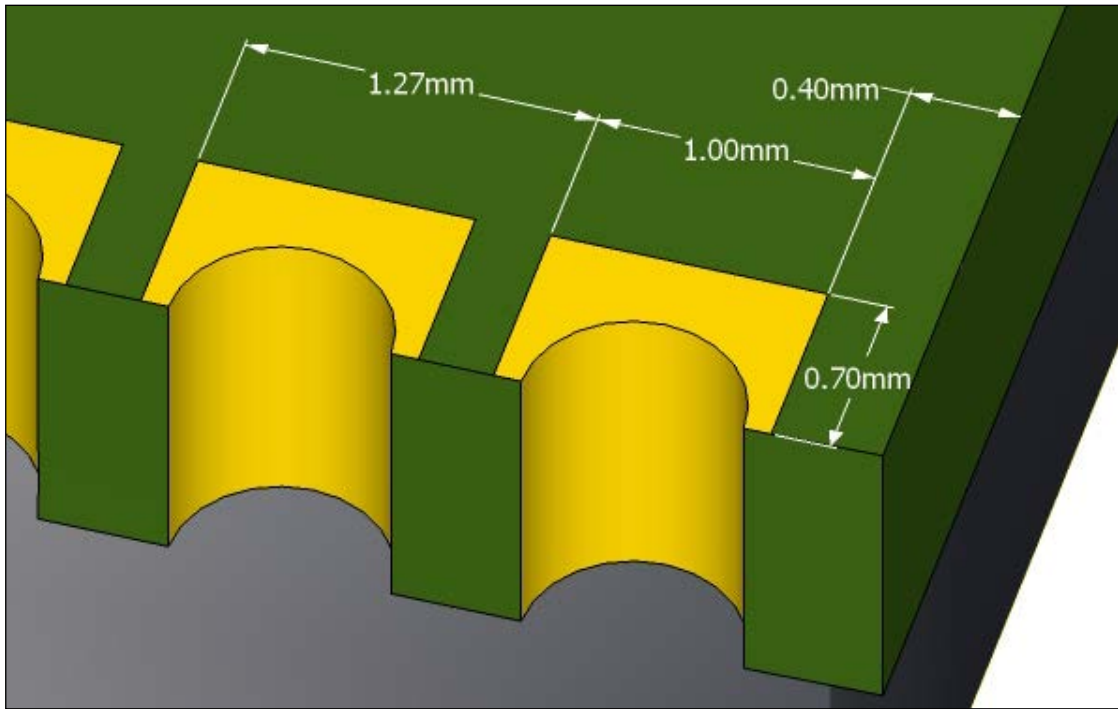

Figure 6. Typical pad dimensions

Module weight: 2.9-3.0g depending on variant

12 Recommended Soldering Temperature Profile

Recommended temperature profile for reflow soldering

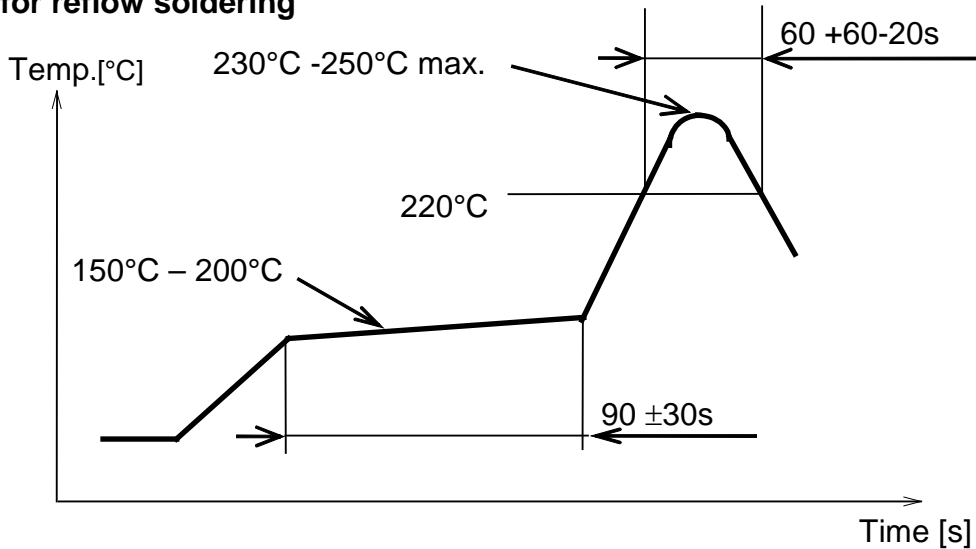

Figure 7. Recommended Reflow Profile

Use of “No-Clean” solder paste is recommended to avoid the requirement for a cleaning process. Cleaning the module is strongly discouraged because it will be difficult to ensure no cleaning agent and other residuals are remaining underneath the shielding can as well as in the gap between the module and the host board.

Please Note:

Maximum number of reflow cycles: 2

Opposite-side reflow is prohibited due to the module’s weight. (i.e. you must not place the module on the bottom / underside of your PCB and re-flow).

13 Product Label Drawing

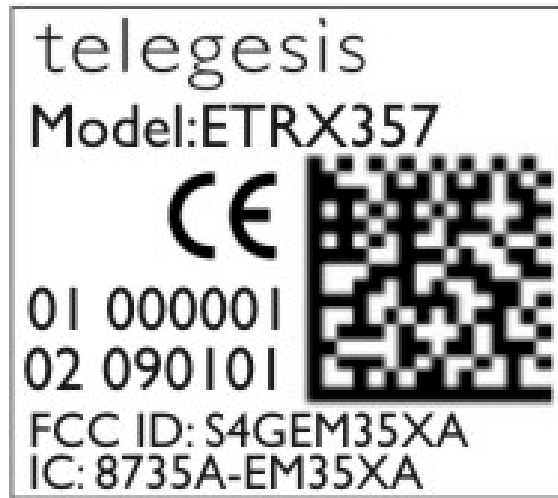

Figure 8: Product Label

The label dimensions are 16.0mm x 14.0 mm. The label will withstand temperatures and chemicals used during a typical manufacturing process.

Imprint	Description
Model:ETRX357	Module Order Code.
000001	Indication for the serial number. Starting at 000000 for each batch incrementing with each module
090101	Production Date Code in the format YYMMDD, e.g. 090101
01	Indication for batch number
02	Indication for the production location (first character) and the hardware revision (second character)
FCC ID: S4GEM35XA	The FCC ID
IC: 8735A-EM35XA	The IC ID
CE	The CE Mark
2D-Barcode	Information in the 2D-Barcode are the serial number [6 characters], the Part-Order code [12 characters filled with trailing spaces e.g. "ETRX357 " instead of "ETRX357"], identifier for the batch number [2 characters], the identifier for the hardware release [2 characters] and the production date code in the format Year-Month-Day [6 characters], separated by a semicolon.

Table 16: ETRX35x Label Details

14 Recommended Footprint

14.1 Pad dimensions

In order to surface mount an ETRX3 series module, we recommend that you use pads which are 1mm wide and 1.2mm high. You must retain the keep-out zone shown in section 12, and ensure that this keep-out area is free of components, copper tracks and/or copper planes/layers.

You must also ensure that there is no exposed copper on your layout which may contact with the underside of the ETRX3 series module.

For best RF performance it is required to provide good ground connections to the ground pads of the module. It is recommended to use multiple vias between each ground pad and a solid ground plane to minimize inductance in the ground path.

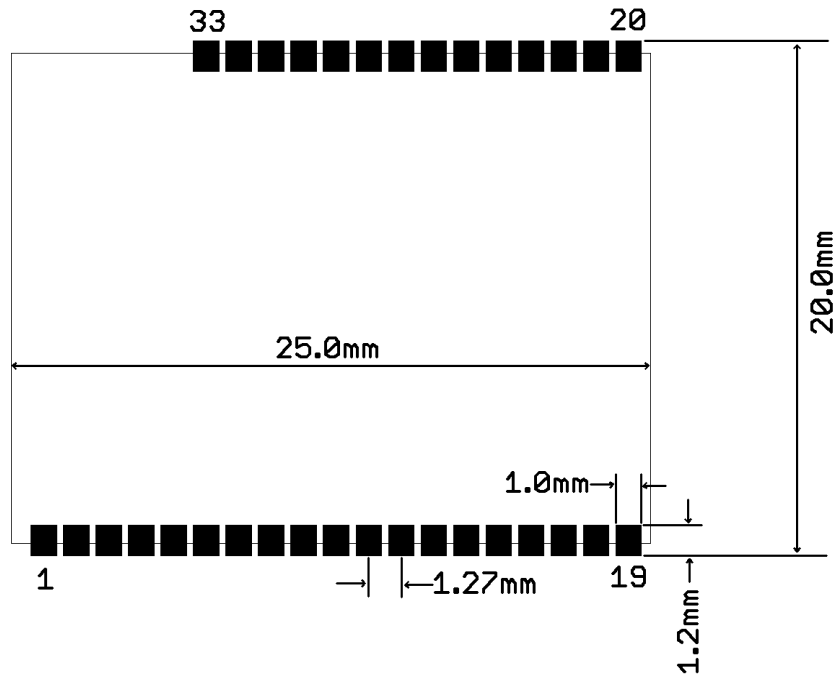

Figure 9: Recommended Footprint

The land pattern dimensions above serve as a guideline.

We recommend that you use the same pad dimensions for the solder paste screen as you have for the copper pads. However these sizes and shapes may need to be varied depending on your soldering processes and your individual production standards. We recommend a paste screen thickness of 120µm to 150µm.

Figure 6 shows the typical pad dimensions of the module and Figure 10 - Figure 12 in section 14.2 show examples of how to align the module on its host PCB.

Although the undersides of the ETRX3 series modules are fully coated, no exposed copper, such as uncovered through-hole vias, planes or tracks on your board component layer, should be located below the ETRX3 series module in order to avoid 'shorts'. All ETRX3 series modules use a multilayer PCB containing an inner RF shielding ground plane, therefore there is no need to have an additional copper plane directly under the ETRX3 series module.

14.2 Recommended Placement

When placing the module please either locate the antenna in the corner as shown in Figure 10 so that the recommended antenna keepout zone is being followed, or add a no copper zone as indicated in Figure 12.

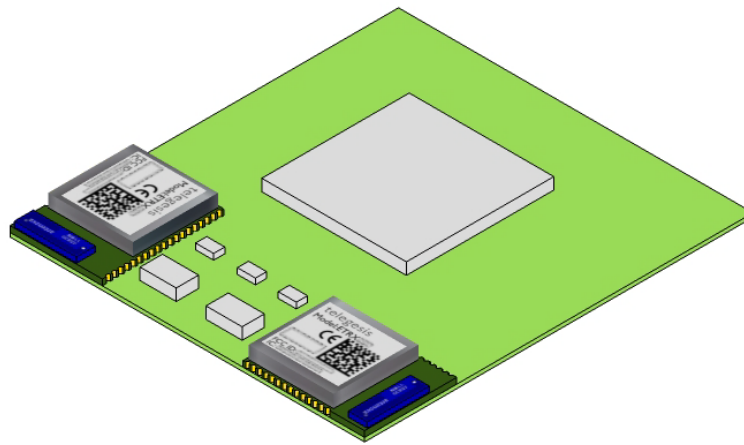

Figure 10. Typical placement

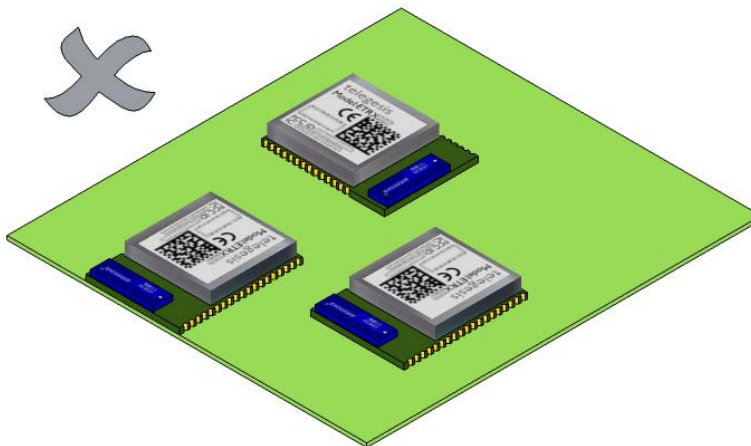

Figure 11. How to not place the Module

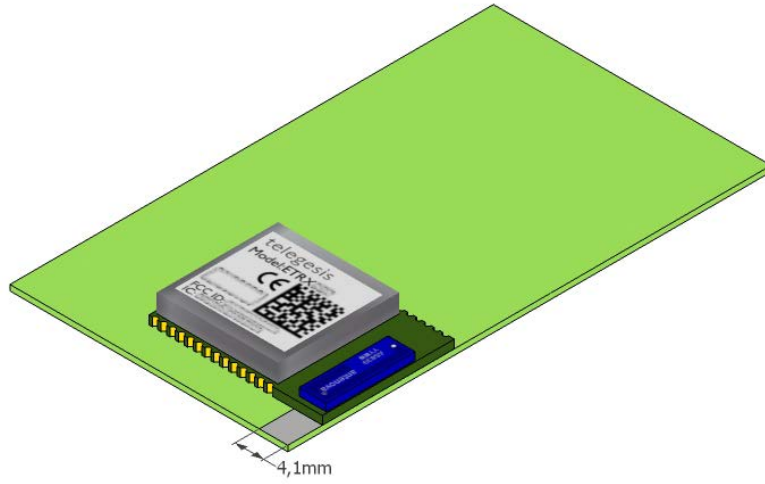

Figure 12. Adding a no copper / no component area

15 Reliability Tests

The measurements below have been conducted on random samples out of mass production and passed after the module has been exposed to standard room temperature and humidity for 1 hour.

No	Item	Limit	Condition
1	Vibration test	Electrical parameter should be in specification	Freq.:40Hz,Amplitude:1.5mm 20min. / cycle,1hrs. each of X and Y axis
2	Shock test	the same as the above	Dropped onto hard wood from height of 50cm for 3 times
3	Heat cycle test	the same as the above	-40°C for 30min. and +85°C for 30min.; each temperature 300 cycles
4	Moisture test	the same as the above	+60°C, 90% RH, 300h
5	Low temp. test	the same as the above	-40°C, 300h
6	High temp. test	the same as the above	+85°C, 300h

Table 17: Reliability Tests

16 Application Notes

16.1 Safety Precautions

These specifications are intended to preserve the quality assurance of products as individual components.

Before use, check and evaluate the module's operation when mounted on your products. Abide by these specifications when using the products. These products may short-circuit. If electrical shocks, smoke, fire, and/or accidents involving human life are anticipated when a short circuit occurs, then provide the following failsafe functions as a minimum:

- (1) Ensure the safety of the whole system by installing a protection circuit and a protection device.
- (2) Ensure the safety of the whole system by installing a redundant circuit or another system to prevent a single fault causing an unsafe status.

16.2 Design Engineering Notes

- (1) Heat is the major cause of shortening the life of the modules. Avoid assembly and use of the target equipment in conditions where the product's temperature may exceed the maximum allowable.
- (2) Failure to do so may result in degrading of the product's functions and damage to the product.
- (3) If pulses or other transient loads (a large load applied in a short time) are applied to the products, before use, check and evaluate their operation when assembled onto your products.
- (4) These products are not intended for other uses, other than under the special conditions shown below. Before using these products under such special conditions, check their performance and reliability under the said special conditions carefully, to determine whether or not they can be used in such a manner.
- (5) In liquid, such as water, salt water, oil, alkali, or organic solvent, or in places where liquid may splash.

- (6) In direct sunlight, outdoors, or in a dusty environment
- (7) In an environment where condensation occurs.
- (8) In an environment with a high concentration of harmful gas (e.g. salty air, HCl, Cl₂, SO₂, H₂S, NH₃, and NO_x)
- (9) If an abnormal voltage is applied due to a problem occurring in other components or circuits, replace these products with new products because they may not be able to provide normal performance even if their electronic characteristics and appearances appear satisfactory.
- (10) Mechanical stress during assembly of the board and operation has to be avoided.
- (11) Pressing on parts of the metal cover or fastening objects to the metal cover is not permitted.

16.3 Storage Conditions

- (1) The module must not be stressed mechanically during storage.
- (2) Do not store these products in the following conditions or the performance characteristics of the product, such as RF performance, may well be adversely affected:
- (3) Storage in salty air or in an environment with a high concentration of corrosive gas, such as Cl₂, H₂S, NH₃, SO₂, or NO_x
- (4) Storage in direct sunlight
- (5) Storage in an environment where the temperature may be outside the range of 5°C to 35°C range, or where the humidity may be outside the 45 to 85% range.
- (6) Storage (before assembly of the end product) of the modules for more than one year after the date of delivery at your company even if all the above conditions (1) to (3) have been met, should be avoided.

17 Packaging

17.1 Embossed Tape

- (1) Dimensions of the tape

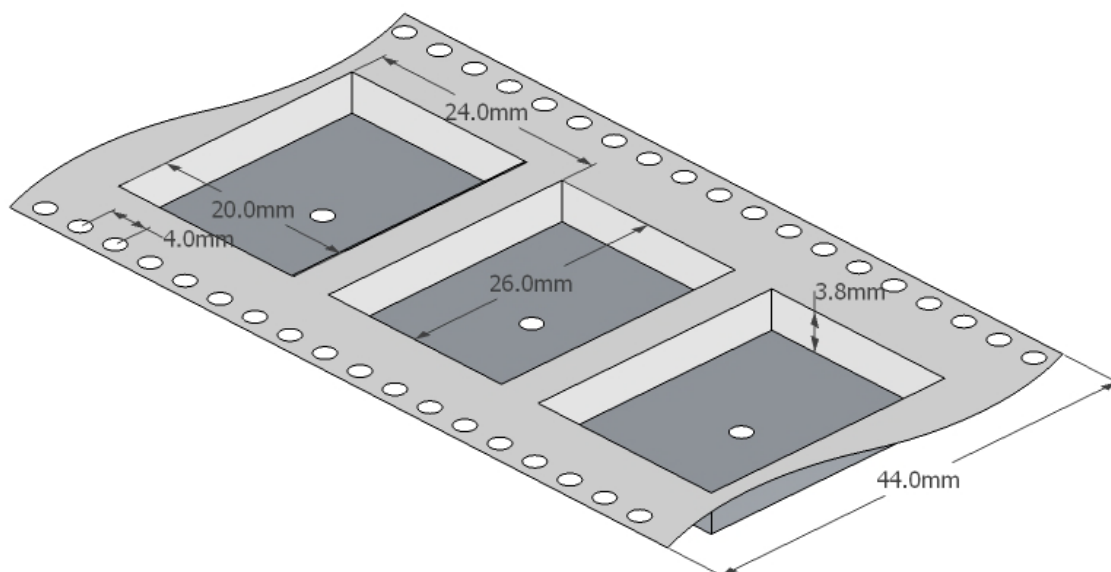

- (2) Cover tape peel force

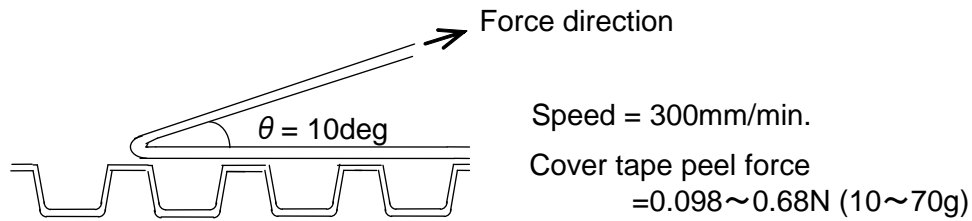

- (3) Empty pockets

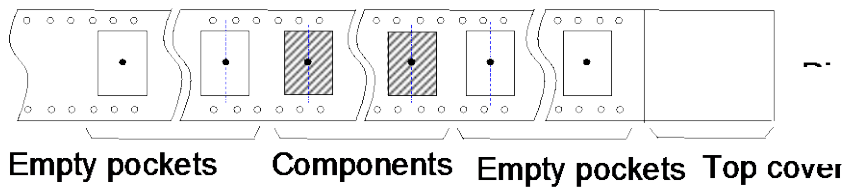

NB: Empty pockets in the populated area will be less than two per reel and those empty pockets will not be consecutive.

17.2 Component Orientation

Top cover tape will not obstruct the carrier tape holes and will not extend beyond the edges of the carrier tape

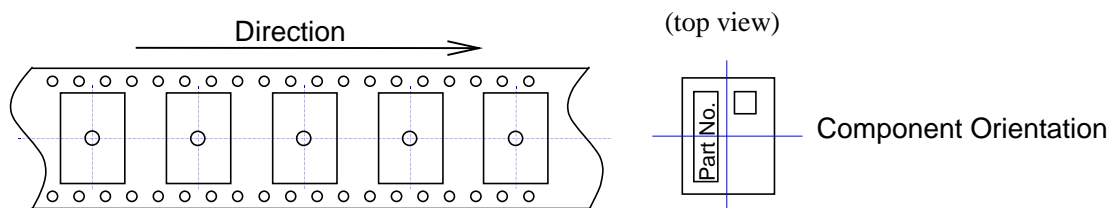

17.3 Reel Dimensions

- (4) Quantity per reel: 600 pieces
- (5) Marking: Part No. / Quantity / Lot No. and manufacturer part# with bar-code will be on the reel

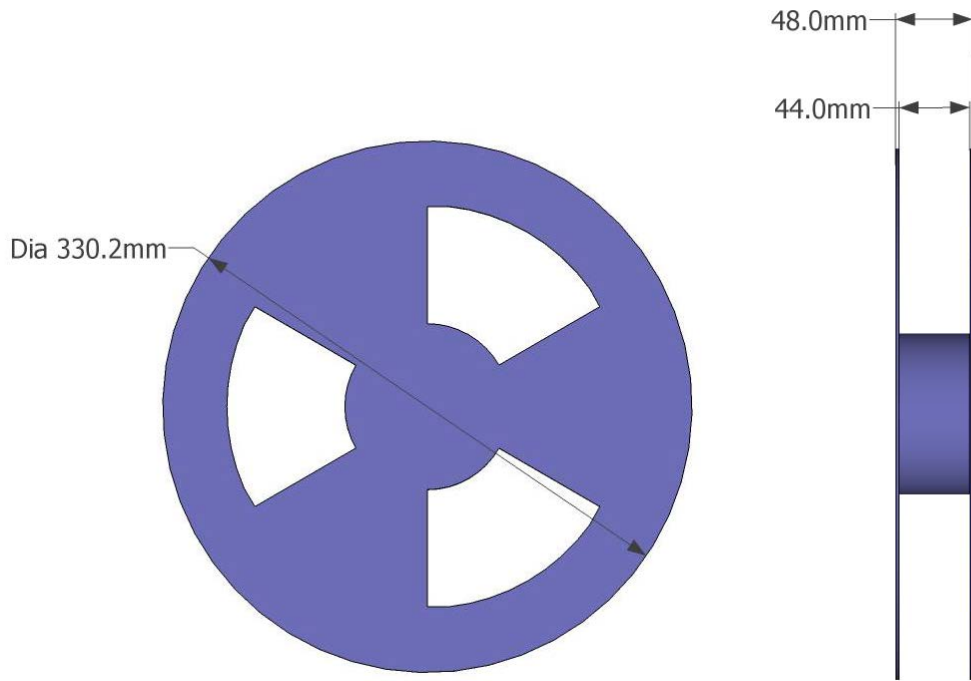

17.4 Packaging - bag

- (6) Each reel will be packed in a hermetically-sealed bag containing desiccant and a humidity indicator card
- (7) Marking: Part No. / Quantity / Lot No. and manufacturer part# with bar-code

17.5 Packaging – carton

- (8) Each reel and bag will be placed in a cardboard carton of nominal dimensions 343 x 338 x 68 mm.
- (9) Weight of carton containing reel of 600 modules: 2.51kg approx.

18 Ordering Information

Ordering/Product Code	Description
ETRX351 ETRX357	<p>Telegesis Wireless Mesh Networking Module with Ember ZigBee Technology:</p> <ul style="list-style-type: none"> • Based on Ember EM351 or EM357 • Telegesis AT Style Command Interpreter based on • EmberZNet meshing and self-healing ZigBee PRO stack • Integrated 2.4GHz Antenna
ETRX351HR ETRX357HR	<p>Telegesis Wireless Mesh Networking Module with Ember ZigBee Technology:</p> <ul style="list-style-type: none"> • Based on Ember EM351 or EM357 • Telegesis AT Style Command Interpreter based on • EmberZNet meshing and self-healing ZigBee PRO stack • U.FL coaxial Antenna Connector
ETRX3DVK	<p>Telegesis Development Kit with:</p> <ul style="list-style-type: none"> • 3 x ETRX35xDV Development Boards • 3 x USB cables • 2 x ETRX35x on carrier boards • 2 x ETRX35xHR on carrier boards • 2 x ETRX35x-LR on carrier boards • 2 x ETRX35xHR-LR on carrier boards • 1 x ETRX2USB USB stick • 2 x ½-wave antennae • 2 x ¼-wave antennae

Notes:

- Customers' PO's must state the Ordering/Product Code.
- There is no "blank" version of the ETRX35x modules available. All Modules are pre-programmed with the Telegesis AT style command interpreter based on the EmberZNet stack. (In case it is desired to program custom firmware the pre-programmed firmware can simply be overwritten).

19 RoHS Declaration

Declaration of environmental compatibility for supplied products:

Hereby we declare based on the declaration of our suppliers that this product does not contain any of the substances which are banned by Directive 2011/65/EU (RoHS2) or if they do, contain a maximum concentration of 0,1% by weight in homogeneous materials for:

- Lead and lead compounds
- Mercury and mercury compounds
- Chromium (VI)
- PBB (polybrominated biphenyl) category
- PBDE (polybrominated biphenyl ether) category

And a maximum concentration of 0.01% by weight in homogeneous materials for:

- Cadmium and cadmium compounds

20 Data Sheet Status

Telegesis (UK) Ltd. reserves the right to change the specification without notice, in order to improve the design and supply the best possible product. Please consult the most recently issued data sheet before initiating or completing a design.

21 Related Documents

- [1] IEEE Standard 802.15.4 –2003 Wireless Medium Access Control (MAC) and Physical Layer (PHY) Specifications for Low-Rate Wireless Personal Area Networks (LR-WPANS)
- [2] Datasheet EM35x, Silicon Labs. (www.silabs.com)
- [3] Datasheet U.FL-Series 2004.2 Hirose Ultra Small Surface Mount Coaxial Connectors - Low Profile 1.9mm or 2.4mm Mated Height
- [4] The ZigBee specification (www.zigbee.org)
- [5] Specification for Antenova Rufa Antenna (www.antenova.com)
- [6] Embedded Antenna design Ltd. (EAD Ltd.) (www.ead-ltd.com)
- [7] Wellhope Communication Equipment (www.wellhope-wireless.com)

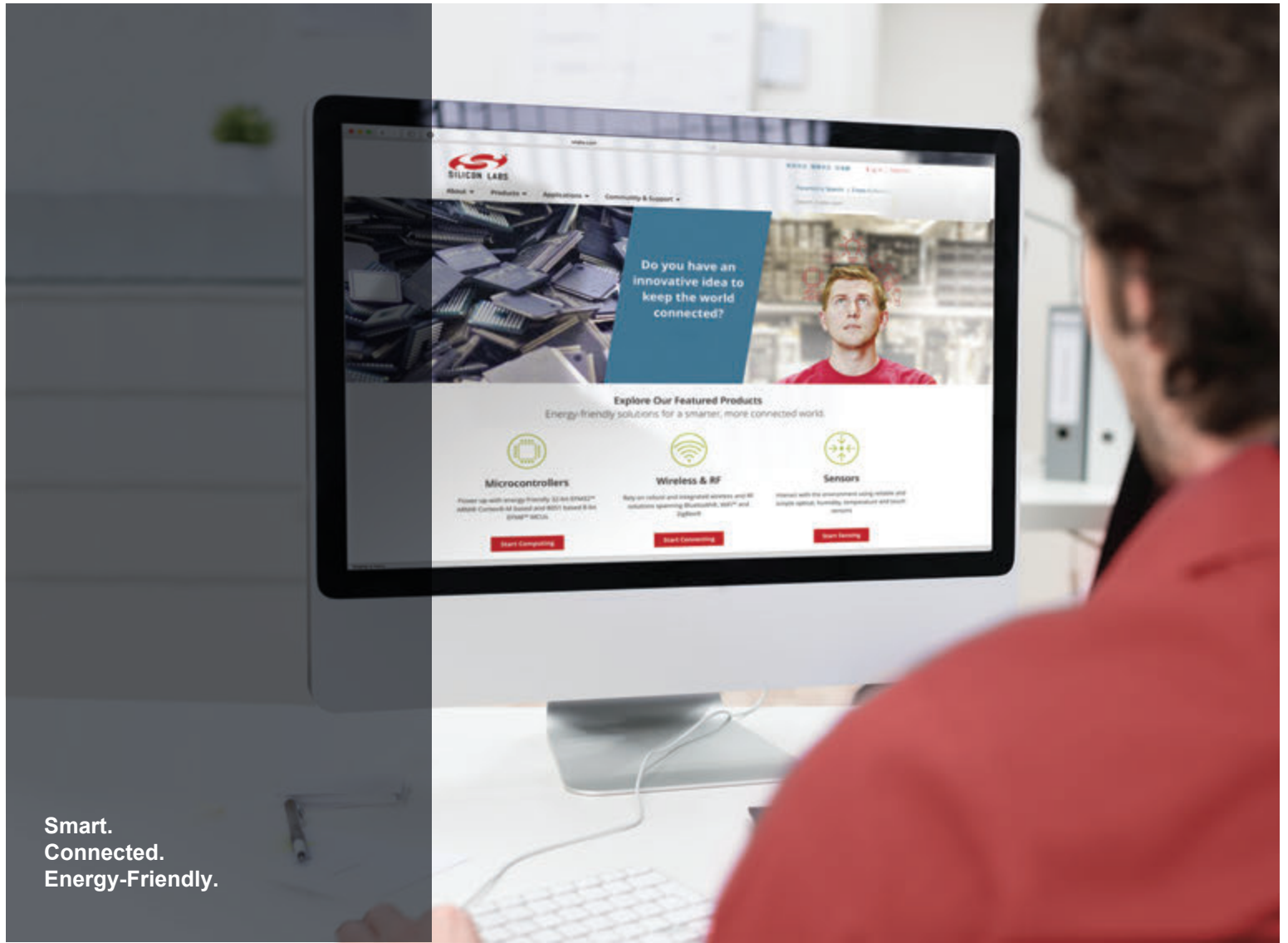

Smart.
Connected.
Energy-Friendly.



Products
www.silabs.com/products

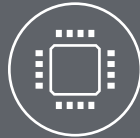

Quality
www.silabs.com/quality



Support and Community
community.silabs.com

Disclaimer
Silicon Labs intends to provide customers with the latest, accurate, and in-depth documentation of all peripherals and modules available for system and software implementers using or intending to use the Silicon Labs products. Characterization data, available modules and peripherals, memory sizes and memory addresses refer to each specific device, and "Typical" parameters provided can and do vary in different applications. Application examples described herein are for illustrative purposes only. Silicon Labs reserves the right to make changes without further notice and limitation to product information, specifications, and descriptions herein, and does not give warranties as to the accuracy or completeness of the included information. Silicon Labs shall have no liability for the consequences of use of the information supplied herein. This document does not imply or express copyright licenses granted hereunder to design or fabricate any integrated circuits. The products are not designed or authorized to be used within any Life Support System without the specific written consent of Silicon Labs. A "Life Support System" is any product or system intended to support or sustain life and/or health, which, if it fails, can be reasonably expected to result in significant personal injury or death. Silicon Labs products are not designed or authorized for military applications. Silicon Labs products shall under no circumstances be used in weapons of mass destruction including (but not limited to) nuclear, biological or chemical weapons, or missiles capable of delivering such weapons.

Trademark Information

Silicon Laboratories Inc.®, Silicon Laboratories®, Silicon Labs®, SiLabs® and the Silicon Labs logo®, Bluegiga®, Bluegiga Logo®, Clockbuilder®, CMEMS®, DSPLL®, EFM®, EFM32®, EFR®, Ember®, Energy Micro, Energy Micro logo and combinations thereof, "the world's most energy friendly microcontrollers", Ember®, EZLink®, EZRadio®, EZRadioPRO®, Gecko®, ISOModem®, Micrium, Precision32®, ProSLIC®, Simplicity Studio®, SiPHY®, Telegesis, the Telegesis Logo®, USBXpress®, Zentri and others are trademarks or registered trademarks of Silicon Labs. ARM, CORTEX, Cortex-M3 and THUMB are trademarks or registered trademarks of ARM Holdings. Keil is a registered trademark of ARM Limited. All other products or brand names mentioned herein are trademarks of their respective holders.



Silicon Laboratories Inc.
400 West Cesar Chavez
Austin, TX 78701
USA

<http://www.silabs.com>